

Worldwide Pollution Control Association

Michigan Coal to Gas Seminar
June 5-6, 2012

All presentations posted on this website are copyrighted by the Worldwide Pollution Control Association (WPCA). Any unauthorized downloading, attempts to modify or to incorporate into other presentations, link to other websites, or to obtain copies for any other purposes than the training of attendees to WPCA Conferences is expressly prohibited, unless approved in writing by the WPCA or the original presenter. The WPCA does not assume any liability for the accuracy or contents of any materials contained in this library which were presented and/or created by persons who were not employees of the WPCA.



Visit our website at www.wpca.info

W
P
C
A





thebabcock&wilcoxcompany

Coal to Gas Conversion B&W Boilers



Don Ryan
Division Mgr, BWSC Engineering

Coal to NG Conversion Burner Options

For coal fired boilers there are four approaches depending on the owner's objectives

1. Completely abandon coal – Replace all burners with new gas burners
2. Retain ability to fire coal – Coal nozzle replacement only with gas elements
3. Retain ability to fire coal – PC burners with gas elements
4. Continue to fire coal – Partial burner replacement/modification

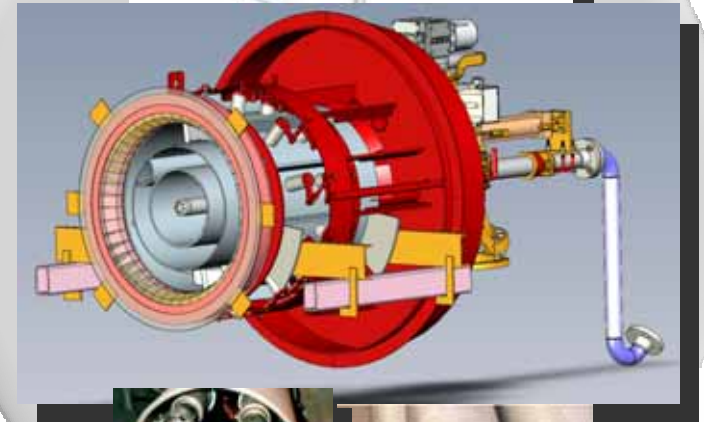
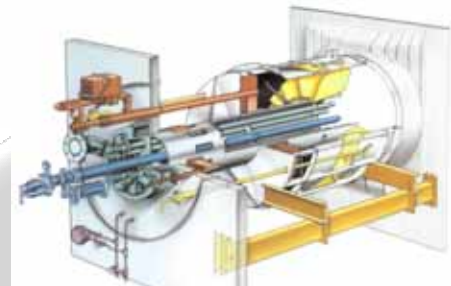

Coal to NG Conversion

Approach 1 – Abandon Coal – Complete Retrofit

- Complete Burner replacement with new gas only burners
- Adjust SH surface (if necessary) to reduce spray flows
- Adjust RH surface (if necessary) to maintain temperature
- Possibly adjust Economizer surface.

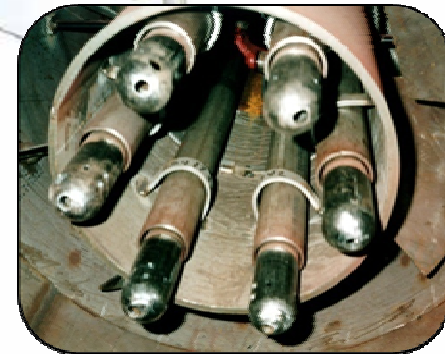
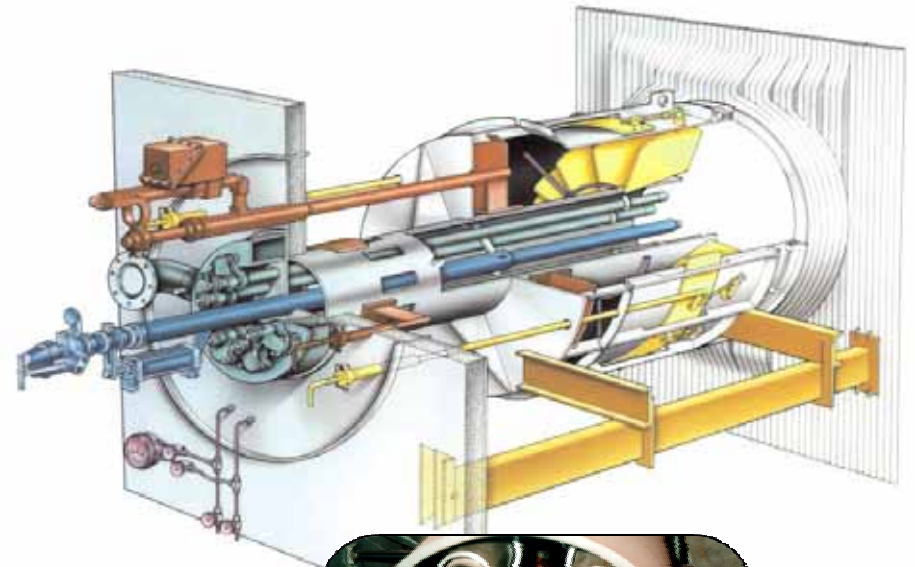

Highest cost & longest outage time

Allows for best combustion and boiler performance



Coal to NG Conversion

Approach 2 – Continue Coal – Coal Nozzle Replacement

Where a unit is already equipped with PC burners, a replacement coal nozzle can be supplied incorporating a gas element

- Lower cost & shorter outage time
- Performance compromises
- Can modify all or some burners
- Pressure part metallurgy must be reviewed
- Provides a hedge against gas curtailments & shortages

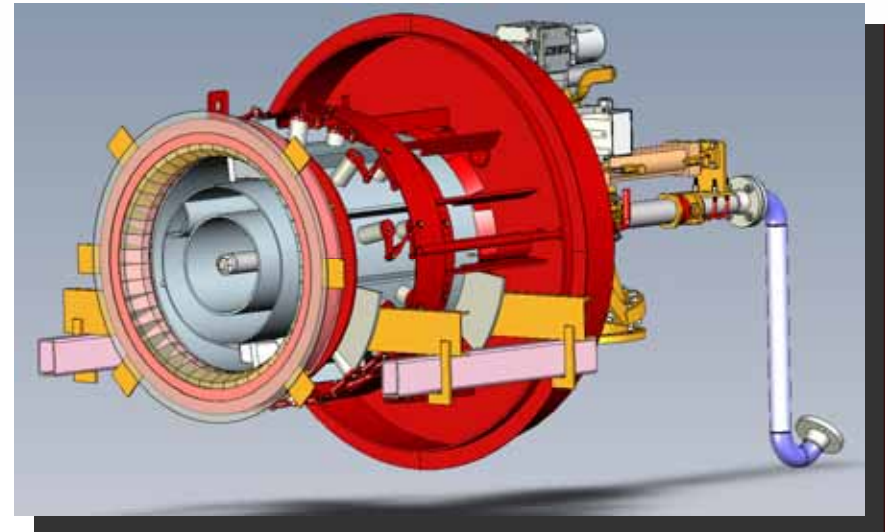

Coal to NG Conversion

Approach 3 – Retain Coal – Burner Replacement

Where existing burners are not suitable for a simple coal nozzle replacement, a complete PC burner with gas elements can replace existing burners

- Higher cost & longer outage time
- Allows for good compromise between fuel flexibility and combustion performance
- Burners can be sized for reasonable pressure drop and/or to accommodate FGR
- Pressure part metallurgy must be reviewed
- Provides a hedge against gas curtailments & shortages

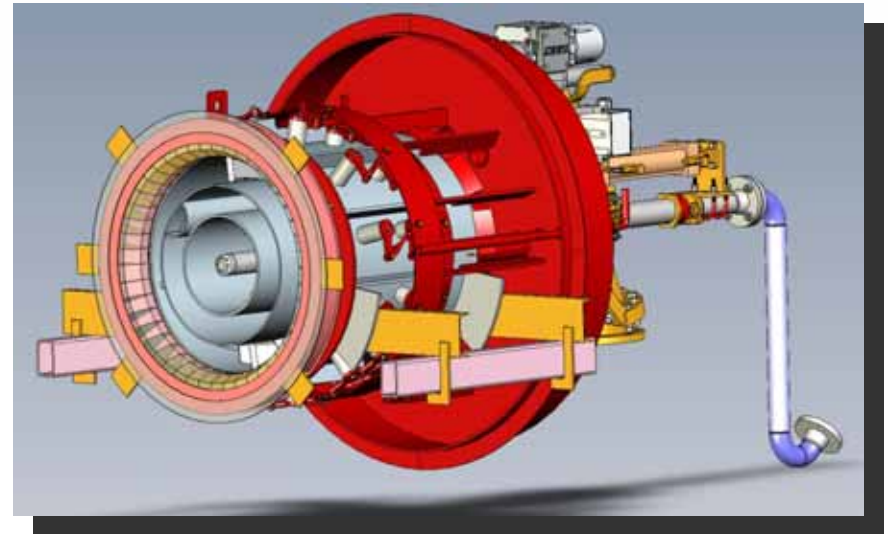

Coal to NG Conversion

Approach 4 – Retain Coal – Augment / Partial Replacement

In some cases where an owner plans to continue to fire coal but would like to augment with gas to lower emissions or improve turndown, some burners can be replaced or modified for gas firing

- More applicable to larger units ($\geq 250\text{MW}$)
- Good tool for turndown improvement
- Can be coupled with change to gas ignitors for incremental increase in heat input on gas

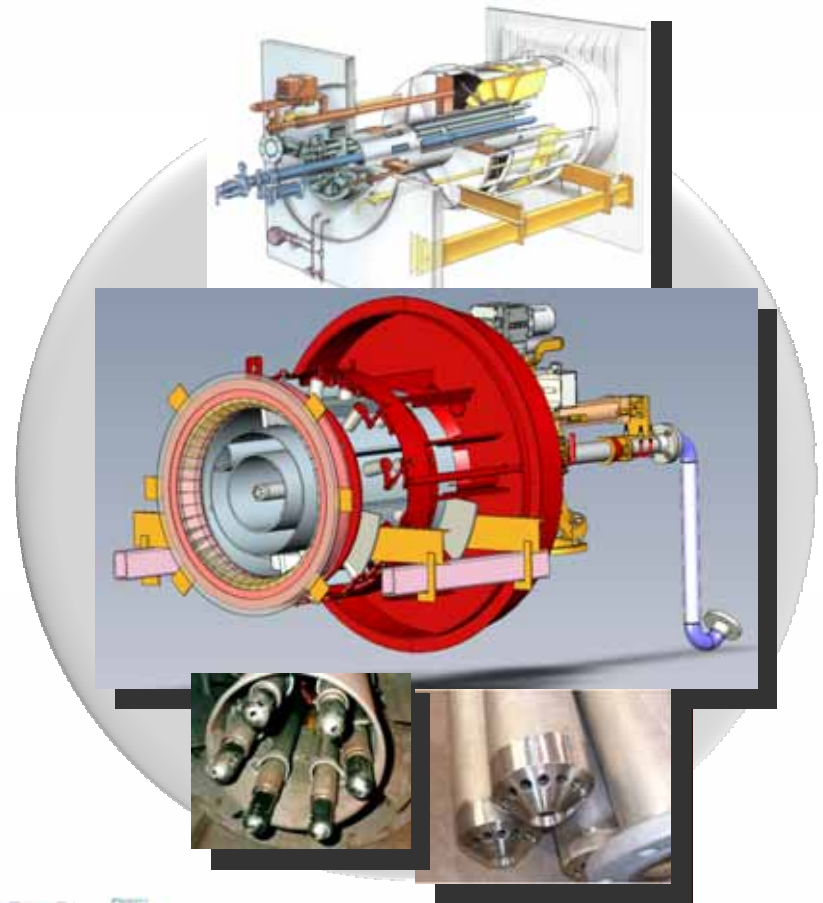

Coal to NG Conversion

NO_x Formation and Control

Fuel Type

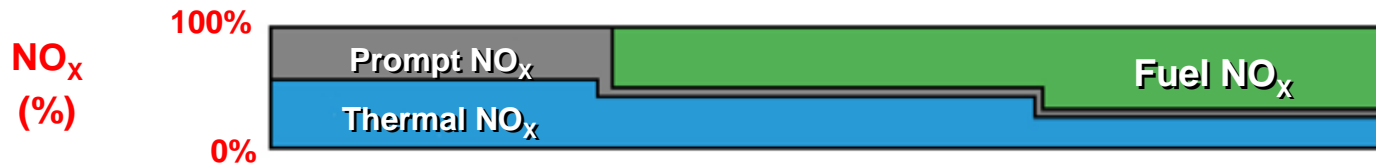

Combustion Method

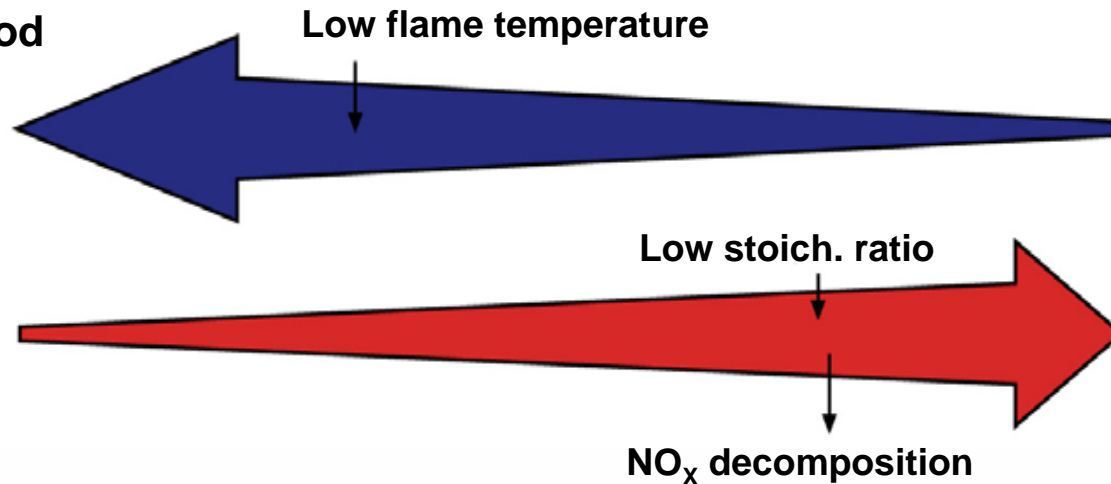

Coal to NG Conversion

NO_x Formation and Control

Thermal NO_x

- ▶ Dissociation & oxidation of nitrogen from combustion air

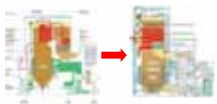

Coal to NG Conversion

NO_x Formation and Control

Thermal NO_x

- ▶ Dissociation & oxidation of nitrogen from combustion air
- ▶ Exponentially dependent on temperature, threshold ~2800F

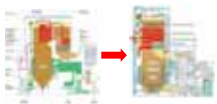

Coal to NG Conversion

NO_x Formation and Control

Thermal NO_x

- ▶ Dissociation & oxidation of nitrogen from combustion air
- ▶ Exponentially dependent on temperature, threshold ~2800F
- ▶ Primary mechanism for NO_x formation from natural gas

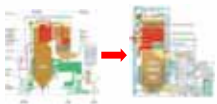

Coal to NG Conversion

NO_x Formation and Control

Thermal NO_x Control Strategies

- Burner Zone release Rate

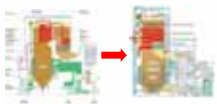

Coal to NG Conversion

NO_x Formation and Control

Thermal NO_x Control Strategies

- ~~• Burner Zone release Rate~~



Coal to NG Conversion

NO_x Formation and Control

Thermal NO_x Control Strategies

- ~~Burner Zone release Rate~~
- Gas Recirculation to Windbox



Coal to NG Conversion

NO_x Formation and Control

Thermal NO_x Control Strategies

- ~~Burner Zone release Rate~~
- Gas Recirculation to Windbox
- Staging

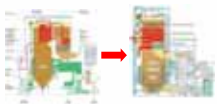

Coal to NG Conversion

Other Burner Scope Items:

- ▶ FGR or IFGR system – depending on NOx performance level desired
- ▶ OFA system – depending on NOx performance level desired
- ▶ Burner throat openings (not common)
- ▶ New ignitors

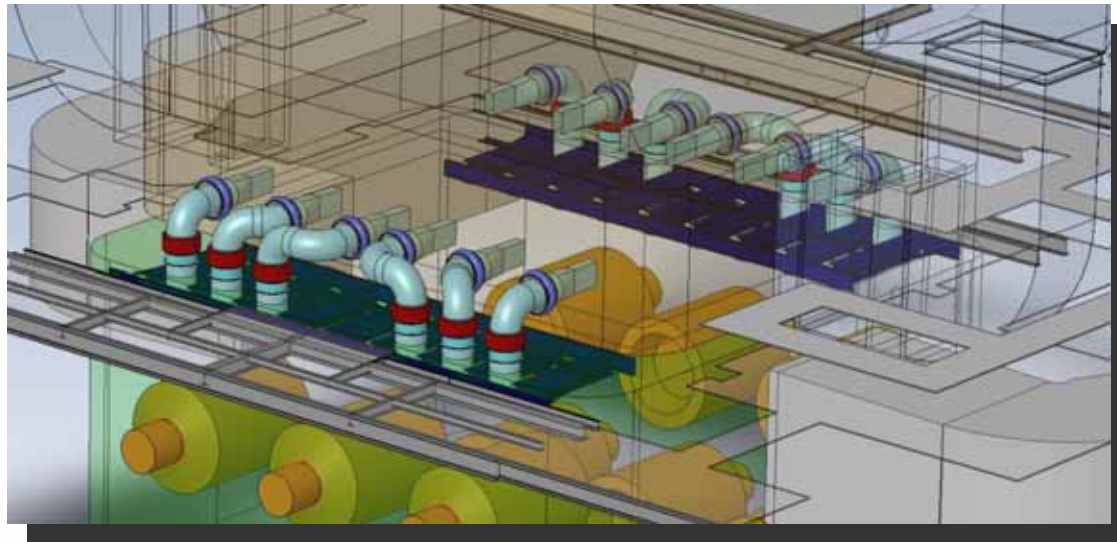

Coal to NG Conversion Equipment Boiler Considerations

Pressure Parts:

- ▶ Convective surface absorptions are higher due to gas weight, gas properties and surface effectiveness



Coal to NG Conversion Equipment Boiler Considerations

Pressure Parts:

- ▶ Convective surface absorptions are higher due to gas weight, gas properties and surface effectiveness
- ▶ Spray attemporator capacities need to be checked

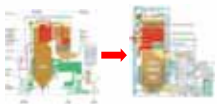

Coal to NG Conversion Equipment Boiler Considerations

Pressure Parts:

- ▶ Convective surface absorptions are higher due to gas weight, gas properties and surface effectiveness
- ▶ Spray attemperator capacities need to be checked
- ▶ PSH, SSH and RH outlet sections often require surface adjustments and/or materials upgrades

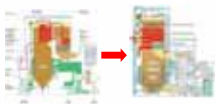

Coal to NG Conversion Equipment Boiler Considerations

Pressure Parts:

- ▶ Convective surface absorptions are higher due to gas weight, gas properties and surface effectiveness
- ▶ Spray attemperator capacities need to be checked
- ▶ PSH, SSH and RH outlet sections often require surface adjustments and/or materials upgrades
- ▶ PSH outlet headers sometimes need to be upgraded

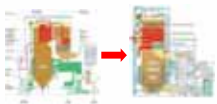

Coal to NG Conversion Equipment Boiler Considerations

Pressure Parts:

- ▶ Convective surface absorptions are higher due to gas weight, gas properties and surface effectiveness
- ▶ Spray attemperator capacities need to be checked
- ▶ PSH, SSH and RH outlet sections often require surface adjustments and/or materials upgrades
- ▶ PSH outlet headers sometimes need to be upgraded
- ▶ Economizer surface may need to be modified to prevent steaming

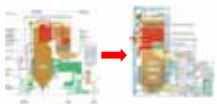

Coal to NG Conversion Air System Considerations

The FD Fan Capacity will need to be checked

- ▶ After a gas conversion, all combustion air must be delivered by the FD fan through the existing Secondary AH and Secondary Air ducts to the windbox and through the burners (and/or OFA system).

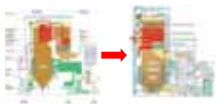

Coal to NG Conversion Air System Considerations

- ▶ **Various Primary/Secondary Air System Configurations exist:**

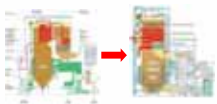

Coal to NG Conversion Air System Considerations

Hot PA

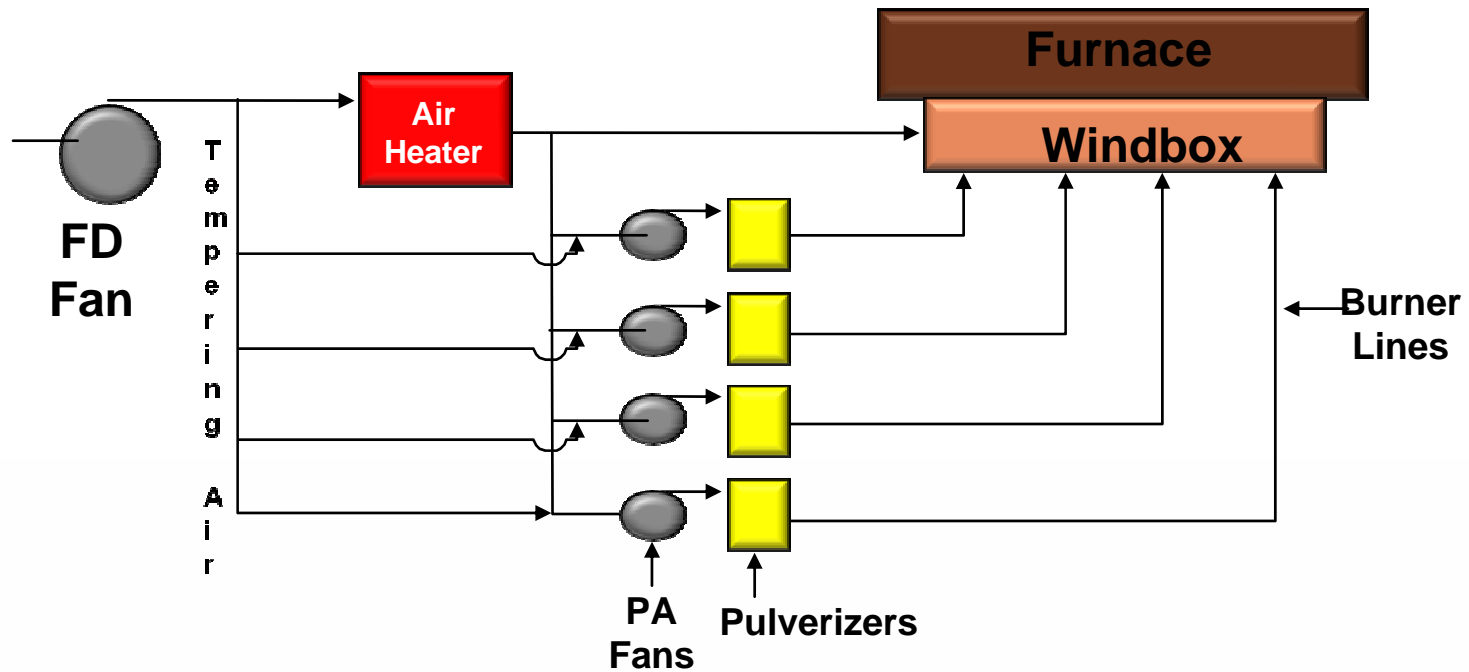

Coal to NG Conversion Air System Considerations Cold PA

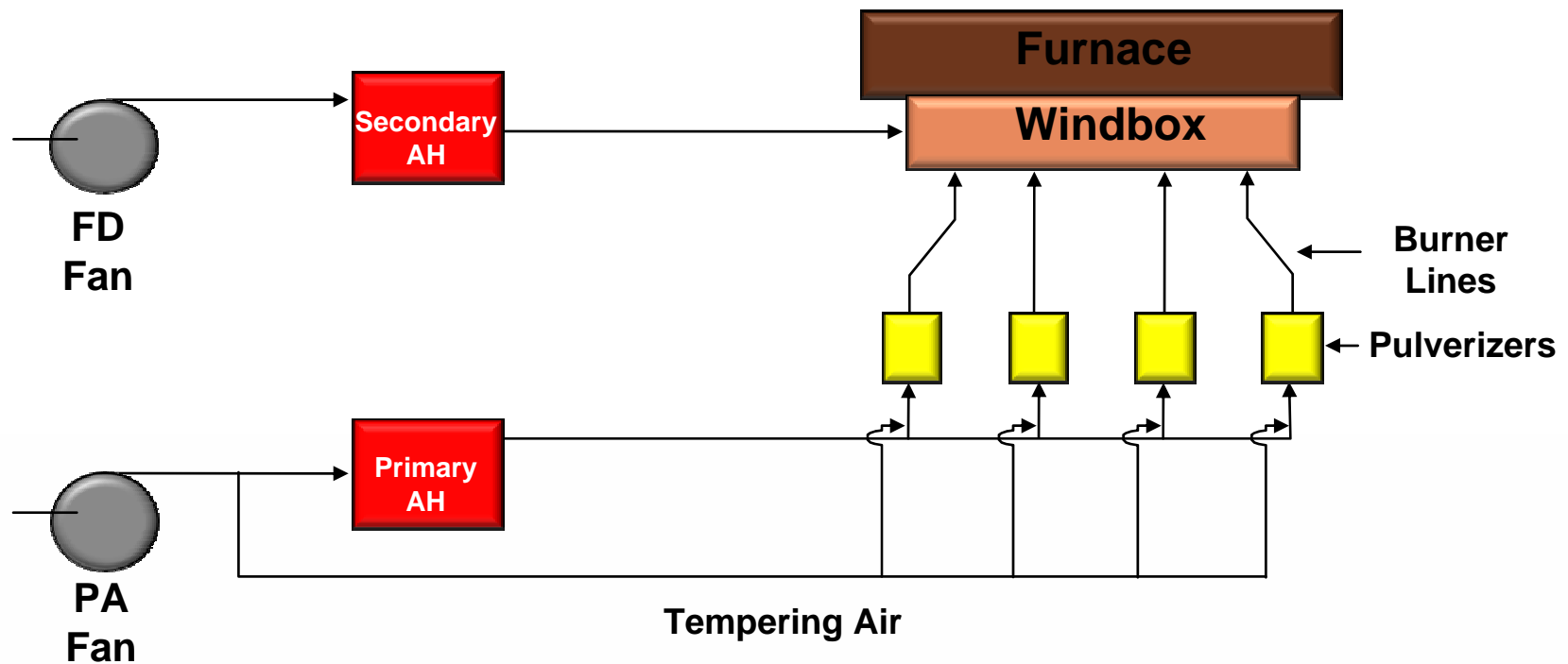

Coal to NG Conversion Air System Considerations Boosted PA

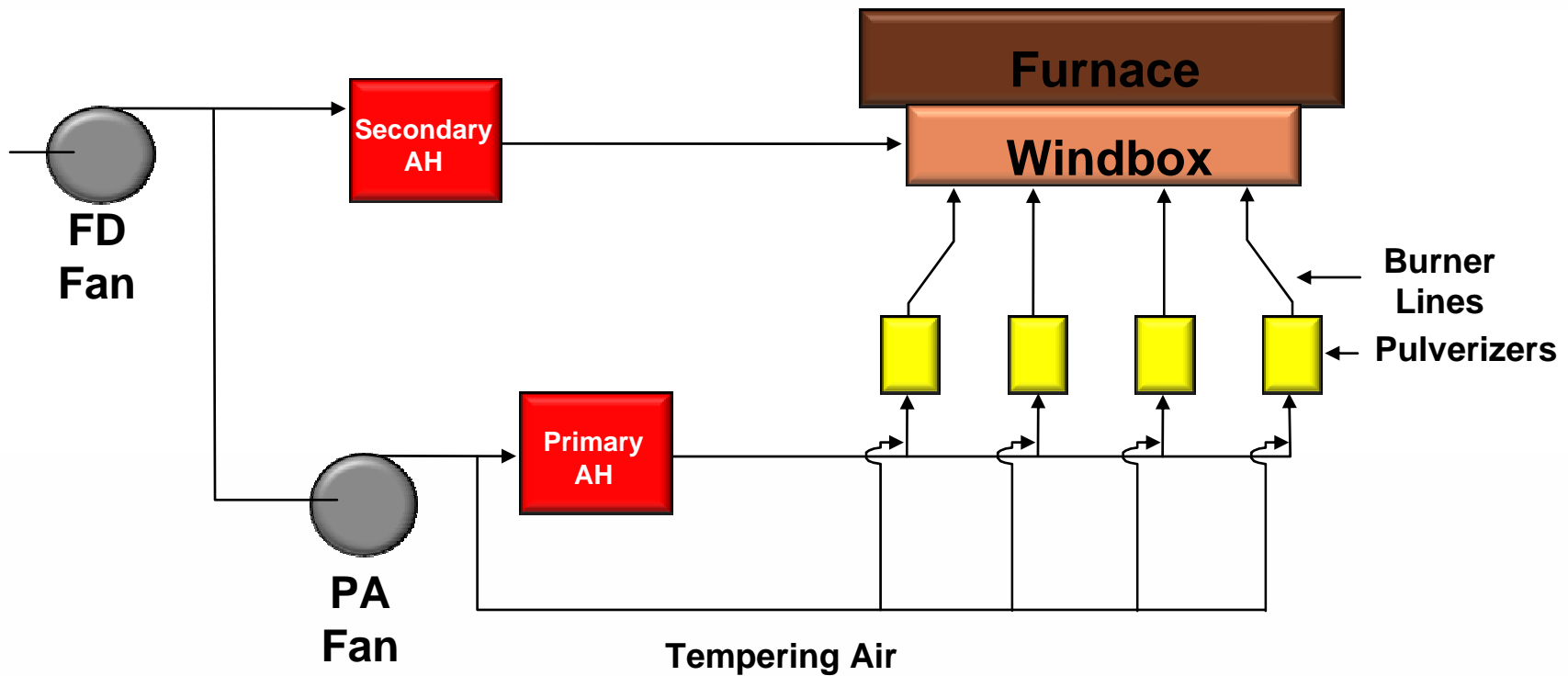

Coal to NG Conversion Air System Considerations

The FD Fan Capacity will need to be checked

- ▶ After a gas conversion, all combustion air must be delivered by the FD fan through the existing Secondary AH and Secondary Air ducts to the windbox and through the burners (and/or OFA system).
- ▶ FGR (if required) will exacerbate the FD fan issues

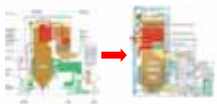

Coal to NG Conversion Air System Considerations

The FD Fan Capacity will need to be checked

- ▶ **After a gas conversion, all combustion air must be delivered by the FD fan through the existing Secondary AH and Secondary Air ducts to the windbox and through the burners (and/or OFA system).**
- ▶ **FGR (if required) will exacerbate the FD fan issues**
- ▶ **The airheater performance should also be checked, especially if IFGR is used for NOx control**



Take Aways

- There are several options for modifying/replacing burners

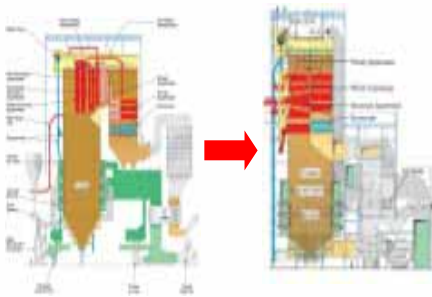

Take Aways

- There are several options for modifying/replacing burners
- Convection Pass heating surface may need modification

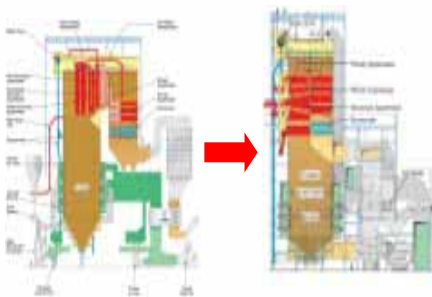

Take Aways

- There are several options for modifying/replacing burners
- Convection Pass heating surface may need modification
- Air system modifications may be required

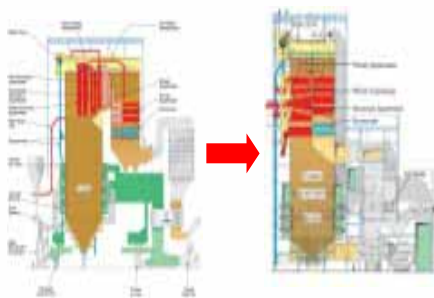

Questions?